



an EnerSys company

METHOD OF PROCEDURE

Correcting auxiliary dry contact wiring on 100A XMBS with factory installed Inverter feeder breaker

Summary

This procedure outlines how to correct 100A auxiliary contact wiring for Inverter feeder breaker on 100A XMBS.

Equipment or Tools Necessary

- Nut Driver
- Pliers
- Allen key set and ratchet
- Torque wrench

Procedure

1. If the XMBS shows Inverter feeder breaker open when it is closed on the LCD (yellow line from Utility to Inverter) when powered, then on the cable harness 8701249-04 GRN and BLU wires on the breaker auxiliary contacts are swapped.

WIRES CONNECTION CHART			
CONNECTOR LABEL	CONNECTOR PIN#	WIRE COLOR	SIGNAL LABEL
INV INP BRKR	1	BLK	NO 'A1'
	2	WHT	COM 'A1'
	3	RED	NC 'A1'
	4	GRN	NO 'B1'
	5	BRN	COM 'B1'
	6	BLU	NC 'B1'
INV OUT BRKR	1	BLK	NO 'A2'
	2	WHT	COM 'A2'
	3	RED	NC 'A2'
	4	GRN	NO 'B2'
	5	BRN	COM 'B2'
	6	BLU	NC 'B2'
UTIL BRKR	1	BLK	NO 'A3'
	2	WHT	COM 'A3'
	3	RED	NC 'A3'
	4	GRN	NO 'B3'
	5	BRN	COM 'B3'
	6	BLU	NC 'B3'

2. XMBS should be de-energized, turn off Utility input breaker in the panel and Inverter output breaker on the AMPS system feeding the XMBS.



an EnerSys company

3. To swap the pins first the breaker must be detached:
 - a. Remove three bolts that hold Breaker to Breaker feed buswork (shown with and without breaker):

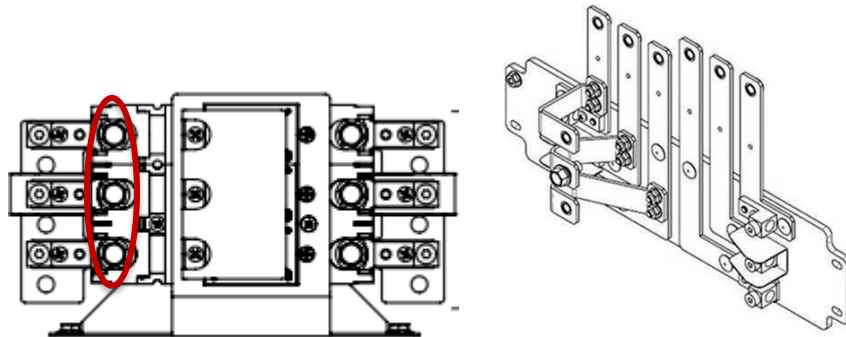

- b. Disconnect output wiring from Inverter Feed Breaker Assembly
Note: This step might not be required if there is enough slack in the output wiring.

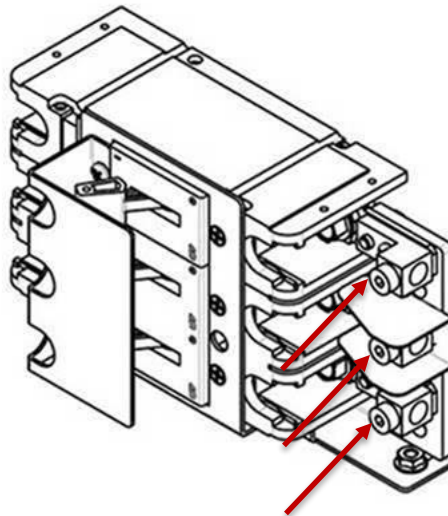



an EnerSys company

4. Loosen (but do not remove) two nuts which hold the bracket onto the bottom of the frame:

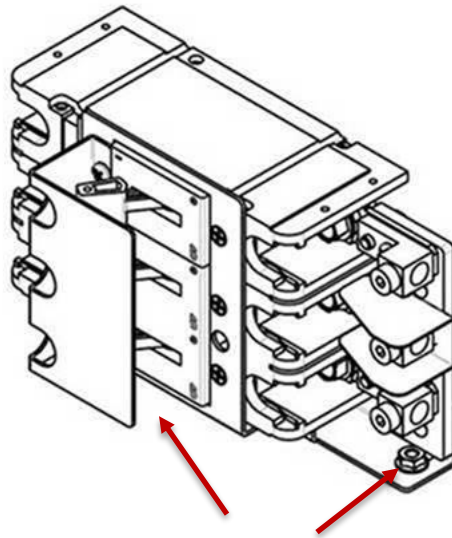

5. Slide the Inverter Feed Breaker assembly forward (away from wall) until the bracket clears the nuts, then tilt forward to expose the back of the breaker.



an EnerSys company

6. Now that the breaker is removed, the wiring can be corrected if reversed.



7. Double check and install wires as below:
- c. Blue: NC (top contact)
 - d. Green: NO (middle contact)
 - e. Brown: C (bottom contact)

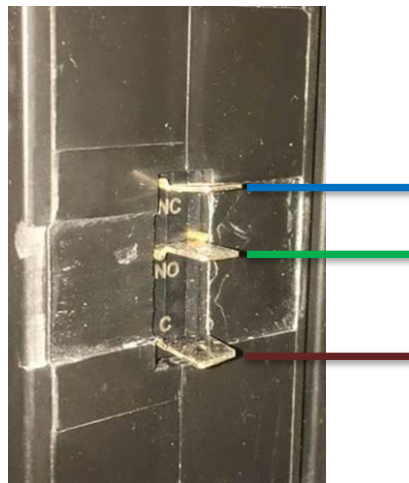



an EnerSys company

- Reassemble by following disassembly steps in reverse order. Torque all fasteners as specified in table below.

IMPERIAL TORQUE VALUES FOR MACHINED FASTENERS (w/o lubrication)											
Imperial	Torque Tool Head Size	Fastener Material									
		Low Carbon Steel (SAE Grade 0-1-2)		Stainless Steel 18-8		Brass		Medium Carbon Heat Treated Steel (SAE Grade 5)		Aluminum and Copper	
		Min. in·lb _f	Max. in·lb _f	Min. in·lb _f	Max. in·lb _f	Min. in·lb _f	Max. in·lb _f	Min. in·lb _f	Max. in·lb _f	Min. in·lb _f	Max. in·lb _f
#2-56		1	2.5	1	2	1	2	n/a	n/a	n/a	n/a
#4-40		3	5	3	5	3	4.5	n/a	n/a	1.7	2.9
#6-32	1/4"	7	9	7	9	6	8	13.5	15	2.9	5.2
#8-32	1/4"	15	18	18	20	14	16	28	30	6	10.5
#10-32	5/16"	27	30	30	32	24	26	45	49	8	13.5
1/4-20	7/16" or 3/8"	62	65	70	75	58	62	99	105	32	45
5/16-18	1/2"	95	130	105	140	78	105	195	225	61	78
3/8-16	9/16"	175	210	190	245	155	190	345	390	105	140
1/2-13	3/4"	380	460	450	530	330	415	840	880	235	300

End of Method of Procedures

For assistance, contact Alpha Technical Support:
 Toll Free North America: 1-888-462-7487
 International: +1-604-436-5547
 Monday - Friday, 7:00 AM - 5:00 PM PST for regular inquires
 24/7 for emergency support
[Click here to report a problem](#)